



## National Electric Code (NEC) “120% Rule”

As a licensed and bonded electrical contractor, the City and County permitting departments hold us to very high standards. One of those standards is to adhere to strict electrical safety guidelines that are published as part of the NEC. One particular rule makes certain that the meter enclosure installed on your home is capable of handling the maximum amount of utility and solar + storage power to your home at the same time. Adding a solar photovoltaic system to your home is like adding a second utility connection on the opposite side of the meter. We must now consider the rating of the meter equipment located between these two power sources, more specifically the bus bar rating. This is commonly referred to as the NEC 120% rule.

When it comes to designing a solar PV or battery energy storage system for any residential property, the 120% rule is used to determine the limit of how much new power generation the site’s electrical infrastructure can safely handle.

Yes, maybe the roof may be able to support several kilowatts of solar PV and you have enough wall space to install a large capacity battery, but can the existing electrical infrastructure handle all of that extra power? This is where you will hear whispers of the 120% rule. Well, what does that even mean?

This rule is meant to calculate how many amps can be back-fed through the customer side of the meter within a measure of safety. In this instance, you have to consider that not only is the solar PV and/or battery energy storage system supplying power to the home but the grid is also present and able to supply additional power to the home from the utility side of the meter. With multiple sources feeding power from opposite ends, what prevents the electrical equipment in the middle of the two from becoming overloaded and possibly becoming a fire hazard? Prior to the installation of the solar PV and/or battery energy storage system, all of the power is supplied from a single source through the home’s main breaker.

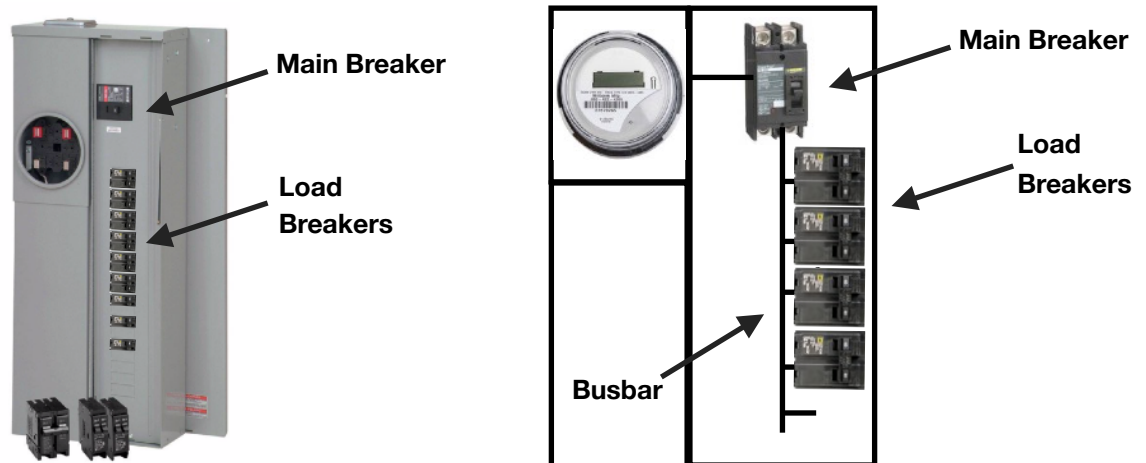

**Example of a home's electrical service meter panel on the left and an illustration view of the same on the right.**

Prior to the installation of the solar PV and/or battery energy storage system, all of the power is supplied from a single source through the home's electrical service. In this example, there is a potential of 250 amps of power draw that could exceed the 200 amp main breaker and bus bar limit. This is allowed under the code because the main breaker would trip and prevent a safety hazard if the load breakers tried to pull more power than the rating of the main breaker.

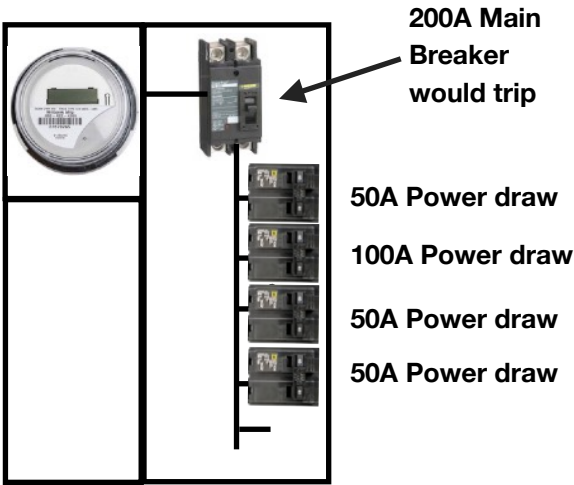

Now, under a similar scenario to the example above, let's now introduce a solar PV or battery energy storage system that can supply additional power from the opposite side of the main breaker supply. There are now two separate sources feeding power from opposite ends and no single protection device that prevents the electrical equipment in the middle (bus bar in this case) from becoming overloaded. In this example, there is a total of 250 amps of power draw that would exceed the safety rating of the busbar, allow it to heat up becoming a serious fire hazard.

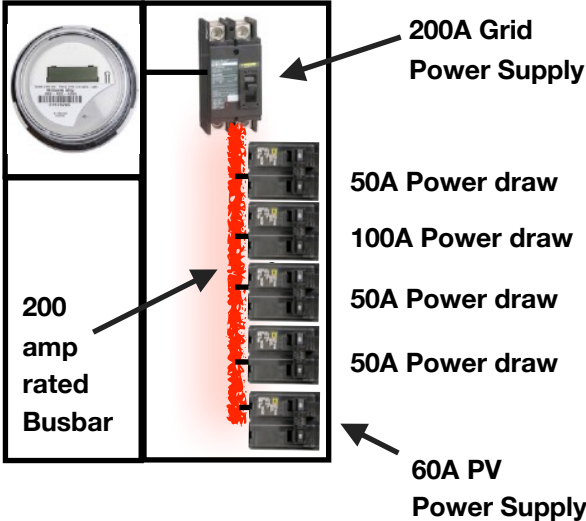

The NEC 120% rule limits the size of additional power sources (PV or battery) to within an acceptable safety limit based on the equipment label rating. In this case, the PV breaker would be limited to a maximum of 40 amps.

$200 \text{ amp rating} \times 120\% = 240 \text{ amps}$

$240 \text{ amps} \text{ minus the } 200 \text{ amp main breaker} = 40 \text{ amps max. for PV breaker.}$

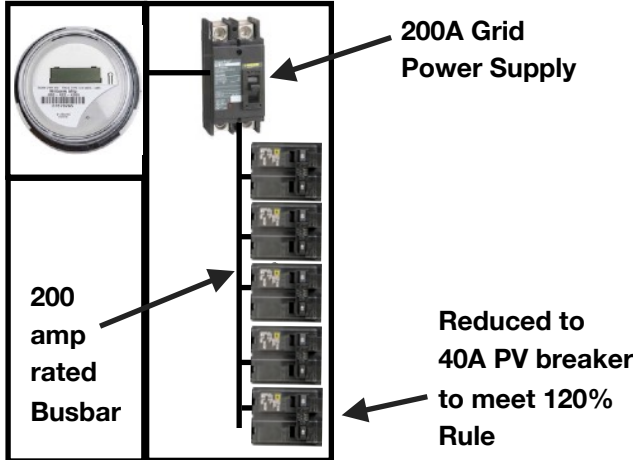

Basically, the NEC 120% rule allows solar PV equipment to be installed in electrical boxes up to 120% of the installed electrical equipment safety label rating. For example, if the home's electrical meter enclosure safety label rating was 200 amps, then this rule allows an extra 20% of wiggle room, or 40 additional amps for solar power.

Unfortunately, this additional 40 amps is not sufficient for many solar PV or battery energy storage systems. A typical PV+Battery installation could require upwards of 60 - 80 amps.

Said another way, with a bit more detail...

NEC code mandates that "The sum of the ampere ratings of overcurrent devices in circuits supplying power to a busbar or conductor shall not exceed the rating of the busbar or conductor". Further, it goes on to allow as much as 120% of a busbar's rating to be exceeded. This is where the calculation comes in to play.

$$(\text{Busbar Rating (A)} \times 1.2) - \text{Main Breaker Rating (A)} = \text{Max (PV + Battery) (A)}$$

Let's start with an example. We have a 200 Amp bus rating for our service panel. In it, we have a 200 Amp main breaker.

$$200\text{A} \times 1.2 - 200\text{A} = 40\text{A}$$

In this example, the maximum output of our PV system can be 40A. This would satisfy the busbar rating without an issue. However, in many instances there is a need or desire to have a much larger system, so what then?

If we exceed the rating of the busbar without regard to the 120% rule, we are creating a scenario where we are feeding a panel board with too much energy and have nothing in place to prevent the sum of the loads in that panel from drawing more current than the busbar can handle.

What do we do in this case? Above all else, we need to have a PV system that is safe and installed to code. What can we do to remedy this and still retain the system size we have targeted?

One solution is to feed the existing main breaker power into a new "sub-panel" that has a higher busbar safety rating. This solution may require additional boxes the side of your home, but it may be a very cost effective solution compared to others.

Another solution may be to downsize the main breaker in your existing service panel. So in our case above we could remove the 200A main breaker and replace it with a 175A main breaker to allow us to install up to 65A of PV. This approach is effective when taking careful consideration of all the existing loads in the home. There could be a potential for these loads to draw close to or more than the amp rating of that 175A breaker.

Alternative solutions could include upgrades to your existing electrical service equipment or possibly a reduction in your overall PV system size to meet the 120% rule guidelines.